

Defiant Diluter™

www.defiant-tech.com

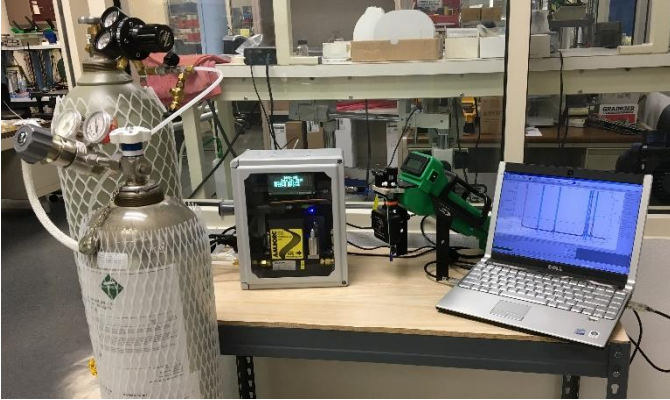

Make Calibration Easy with a BASS-100 Diluter

Instrument Specifications	
Dilution Air	0 – 5000 mL/min
Standard Gas	0 - 100 mL/min
Weight	7.7 kg (17 pounds)
Dimensions	12" x 12" x 6" (31x31x16 cm)
Power:	12 VDC x 2 Amp , AC wall adapter

Defiant Technologies, Inc.

6814A Academy Parkway W NE

Albuquerque, NM 87109

www.defiant-tech.com

(505) 999-5880

sales@defiant-tech.com

Publication 20180725



Defiant Technologies' Automated Calibration Gas Dilution System BASS-100



**Automatically Mix it Up with
the BASS-100 Calibration Gas
Dilution System
by Defiant Technologies, Inc.**

Hand-Held Gas Chromatography Made Simple



One Gas Standard – Infinite Concentrations

Features:

- ✓ Seamless Interface with Ellvin™ Software
- ✓ Automatic Operation at Multiple Calibration Points
- ✓ Charcoal Trap Scrubs Excess Calibration Gas Flow
- ✓ Runs on 110 VAC with AC Adapter
- ✓ 500:1 Dilution Capability
- ✓ Heated Mixing Line for Faster Stabilization

Easy to Use:

- Software provided to calculate concentrations
- Sets up in minutes
- Simple quick start guide

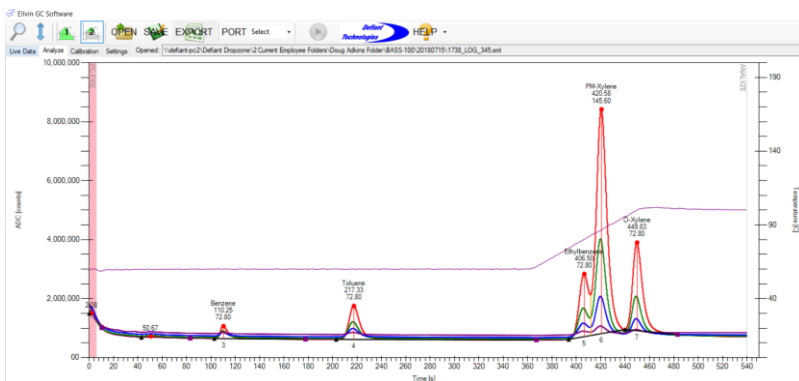

Applications:

- Perform multipoint calibrations for gas analyzers
- Supply single point calibration check
- Fill sample bags for field bump tests

Includes:

- Reliable Mass Flow Controllers (MFC)
- Microprocessor Controller
- Interface Software Provided
- Display Shows Operation Steps
- USB-Serial Adapter Cable
- Power Supply (12VDC, 2 Amp)

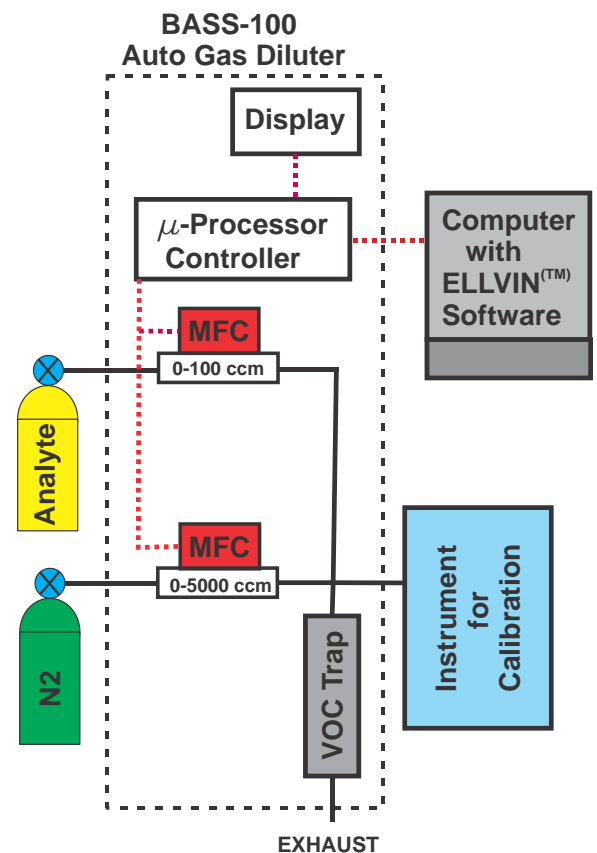

Advantages:

- Eliminate need for sample bags
- Uses less calibration gas
- Use one calibration standard and provide multiple concentrations for calibration
- Provides cleaner baseline than sample bags
- Multiple-point calibration data generated automatically